



INFRARED THERMAL TECHNOLOGY

CAMERA & SOLUTION GUIDE



SOLUTIONS · INFRARED CAMERAS · SERVICES

EMITTED ENERGY
Infrared Thermal Technologies

EMITTED

Emitted Energy is an industrial automation solutions provider specializing in the application of infrared technology. We help improve our customers' bottom line by providing robust, turnkey solutions, high quality products, & comprehensive services utilizing infrared thermal machine vision & infrared non-contact heating elements.



We are proud to be a:



Using FLIR thermal cameras, we provide solutions that positively impact our customers bottom line with quality inspection and control with our Thermal Process Monitoring System (TPMS). Whether you need an Integrated TPMS, a Versatile TPMS testing unit, or you're looking to utilize our solution mobility with our Travel TPMS, we will work with you to deliver the best thermal imaging solution available. Contact us for more information on the value of Emitted Energy's TPMS & non-contact integrating precision heating.

OUR VISION

Our market vision is to be the premier supplier of integrated infrared technology and infrared quartz heating elements with a strong focus on providing elite service & unsurpassed quality.

ENERGY

We believe partnerships and relationships are a key foundation that holds our businesses together. We value these partnerships, and recognize each of our customers as a member of our organization. As such, we view our customers as key stakeholders and valued members. Everyday we continue to bring our vision to life as we passionately strive to provide world-class solutions, services and infrared products.

How do we do this?



1. LISTEN We listen to understand your application needs & requirements.



2. ENGINEER Through the listening process, we engineer the right-fit solution to meet your needs.



3. PARTNER We partner with you to integrate your full turn-key solution.



4. SUPPORT We understand that a purchase order is the beginning, not the end of a relationship.

WE ARE HERE TO SUPPORT YOU

PLASTIC JOINING

Are your processes being optimized with Closed Loop Process Control Capabilities? Are you still seeking solutions for quality control and sustainability? Thermal Machine Vision Solutions are the #1 solution being used by Plastic Processors today. Our solutions are used throughout the manufacturing process to inspect and analyze areas where heat is critical.

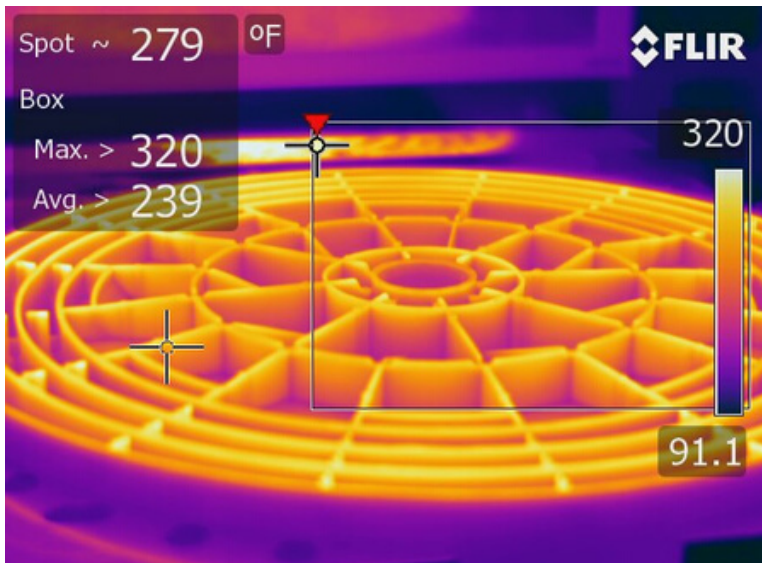

Validate your welding processes that use technologies like vibration, ultrasonic, lasers, infrared, hot air/cold stake and more. Experienced in deploying solutions for 100% inline part and process quality control using Non-Destructive Testing methods and machine integrated Infrared Thermal Automation Cameras and our own TPMS.

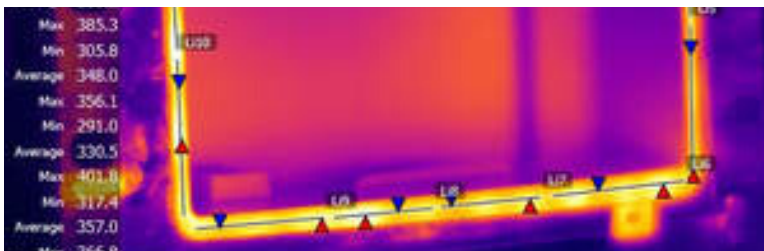

ADHESIVES & SEALANTS

Are your processes being optimized with automated inspection for quality control and sustainability? Thermal Imaging may be used to inspect any process in which heat is a critical factor. Applications which entail dispensing a black adhesive on a black substrate or where clear adhesives are dispensed at all have proven challenging for standard machine vision systems to analyze.

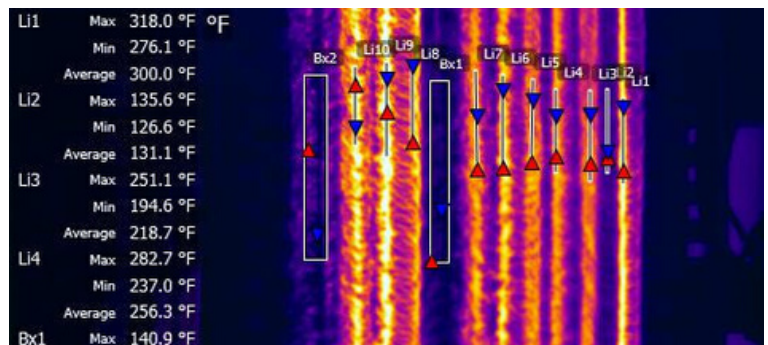

Thermal machine vision systems which rely on radiometric analysis instead of standard vision give your solution the unique capability to easily inspect and analyze processes which may prove challenging using other machine vision providers. Experienced in deploying solutions for 100% inline inspection ensuring optimal quality control using Non-Destructive Testing methods

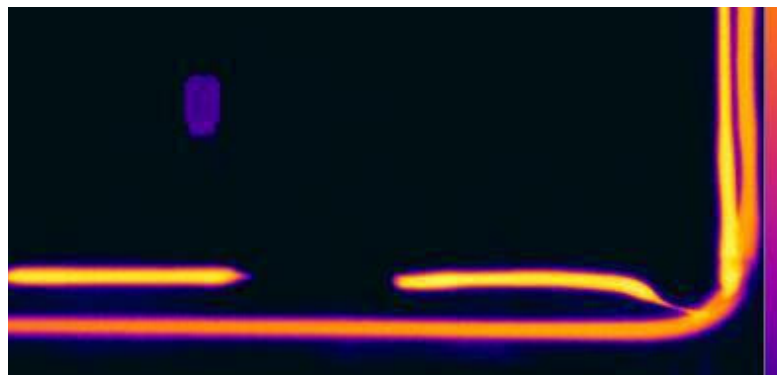

INJECTION MOLDING

Has your Injection molding process been optimized? Allow our Master Molders, using a scientific molding set up, and a statistical design of experiment to analyze your current process. We provide in-house support at your facility and work directly with your team to remove any problems with dimensional, ecstatic, and performance criteria, at the same time, ensuring you are molding at your fastest cycle time possible.

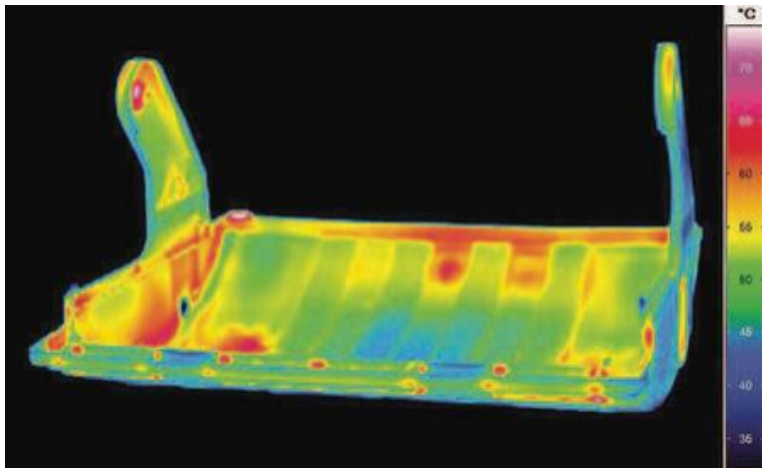

Thermal Imaging is used to inspect any process in which heat is critical. Automatically inspect your molding process for part to part consistency and achieve true optimization through our unique experimentation process. During this process, you will work alongside our team of experienced automation and manufacturing professionals including certified thermographers, master molders and Gold Tier FLIR Automation Technology Partners. Experienced in deploying solutions for 100% inline part and process quality control using Non-Destructive Testing methods and machine integrated Infrared Thermal Automation Cameras and our own TPMS.

PACKAGE PROCESSING

Are your processes being optimized with automated inspection for quality control and sustainability? Thermal Imaging may be used to inspect any process in which heat is a critical factor. Easily inspect your packaging process when using paper, various plastics, and even challenging materials like glass, metals, etc.



We offer solutions for packaging and sealing processes including leak detection for hermetic sealing processes and air cushions, even early fire detection for corrugated manufacturing slitter machines, and more is possible. Experienced in deploying solutions for 100% inline part and packaging quality control using machine integrated FLIR A-Series Cameras and our own TPMS.

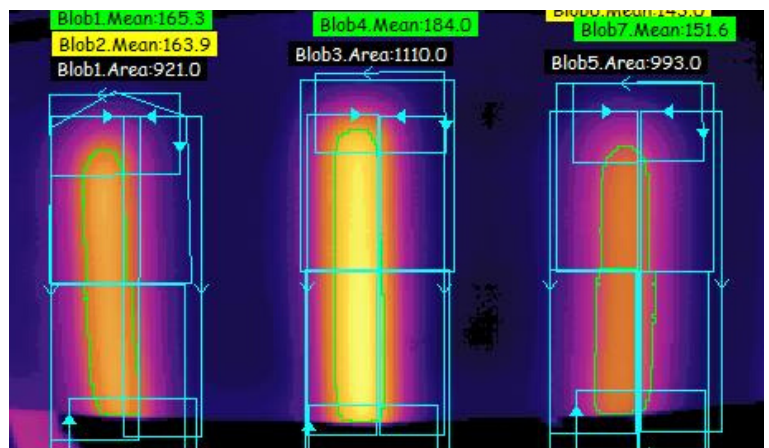

T H E R M O F O R M I N G

Are your processes being optimized with Closed Loop Process Control Capabilities? Thermal Machine Vision Solutions are the #1 solution for thermoformers being used today. Our systems inspect the thermal profile of composite sheets while they are shuttled from the heating field to the mold cavity. This analysis can be used to send feedback to the machine allowing your PLC to adjust your heating zones accordingly.

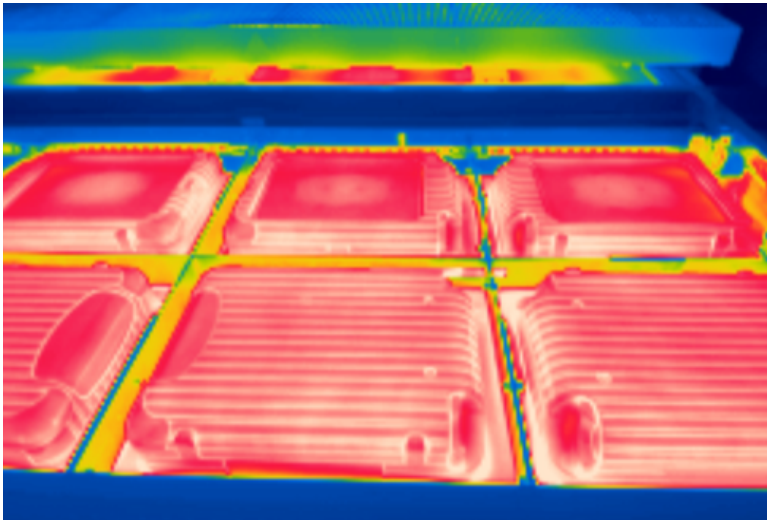

Our solutions are used throughout manufacturing to inspect and control processes in which heat is a key component of producing quality parts. Experienced in deploying solutions for 100% inline part and process quality control using Non-Destructive Testing methods and machine integrated Infrared Thermal Automation Cameras and our own TPMS..

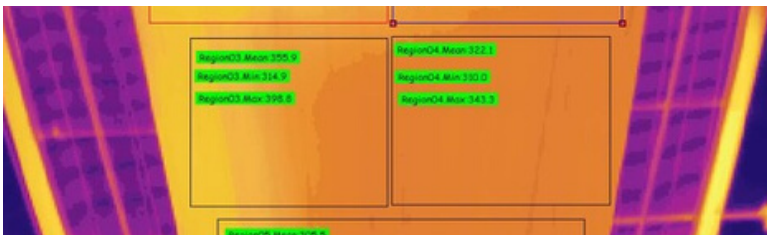

EARLY FIRE PROTECTION

Our state-of-the-art EFD systems are perfect for warehouses, manufacturing plants, coal fields—anywhere valuable material is stored. Fires progress through four stages: the incipient (the "ignition") stage, the growth stage, the fully-developed stage, and the decay stage. Typically, fire detection systems detect fires at the growth stage, since that is when smoke begins to be noticeable; traditional fire suppression systems, such as sprinklers, are not activated until this happens, by which point the fire has grown considerably.

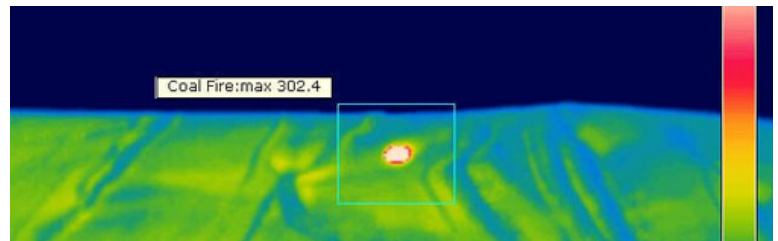

This means the fire has already damaged a portion of your valuable materials, costing you thousands of dollars. Our Early Fire Detection solution can detect fires at the incipient stage by identifying hotspots and can autonomously alert you of such locations. In this way, fires are prevented even before they begin, saving you those precious, valuable materials and thousands of dollars in damage. Contact us to find your EFD solution.

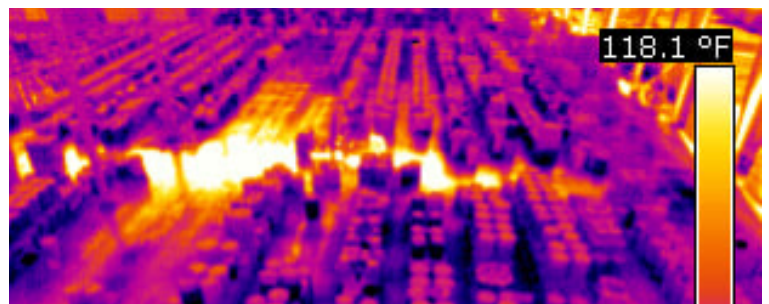

THERMAL PROCESS MONITORING

with  FLIR

Your Operation

FLIR IR Cameras observe the thermal profile of your process & pass radiometric data to the TPMS for analysis.

1

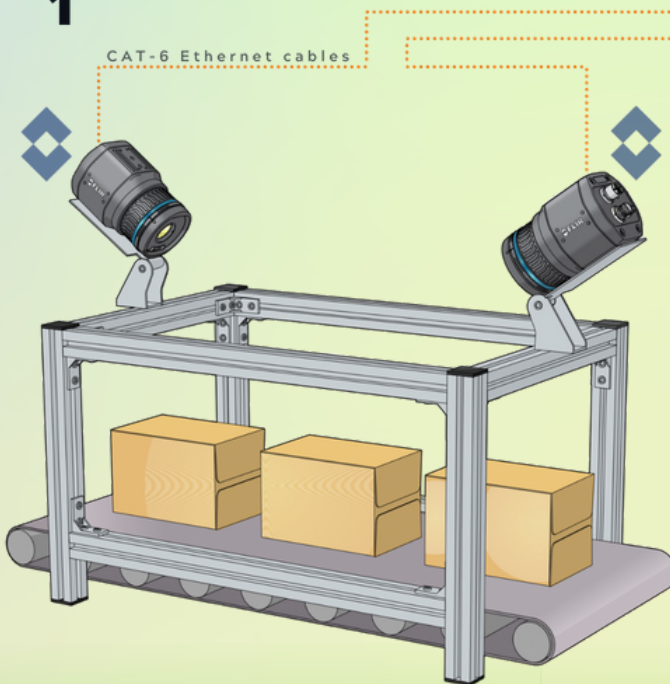

Inside of the TPMS

Utilizing the Enlighten™ Software, the TPMS uses your process using limitless Regions of Interest

2

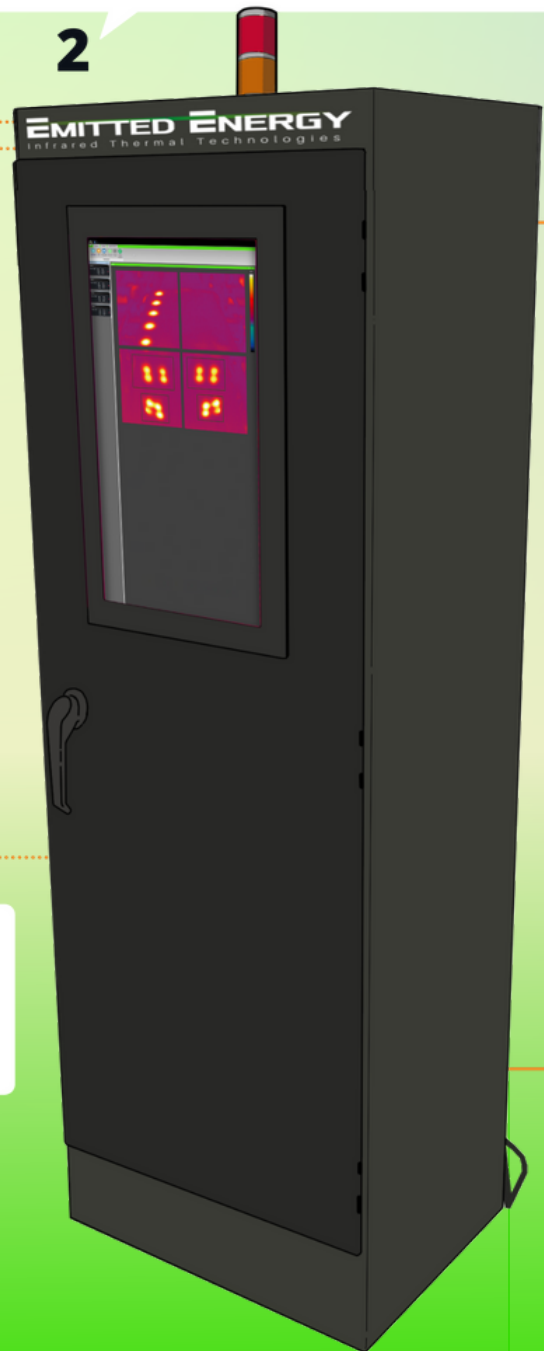

Direct
When
can be

3

Data to PLC means valuable adjustments

The PLC receives data from the TPMS enabling automatic adjustments in the process and alerting operators and managers to process variation and faults.

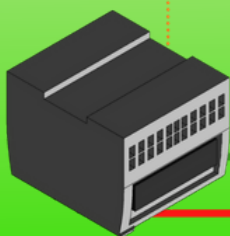

PLC
Programmable
Logic Controller

PASS APPROVE

FAIL REJECT, ADJUST, etc.

Thermal
pivot
report
image

MONITORING SYSTEM

IR cameras

Set your custom parameters to identify faults in
to monitor, alarm, & send triggers to the PLC.

Alerts

When a parameter is unmet or exceeded, an alert
is sent to any device to notify pertinent parties.



Real Data gathered around the clock provides
all information on your process; .CSV data
reports, graphs, trends, averages, archives, thermal
images, inter alia.



THE SOFTWARE



ENLIGHTEN™ Intuitive
software provides
real-time monitoring,
data acquisition and
imaging analysis of
industrial processes.

- Early detection of anomalies increases safety for plant personnel and reduces risk of damage to plant equipment
- Increase revenue with full automation
- Reliable source of critical data for engineers
- Easy integration into existing plant control system

FLIR AX8



FLIR AX8

Features

Automatic Analysis and Alarms

With its streaming video output, the AX8 not only gives you live video of every installation, but it also provides automated alarming when pre-set temperature thresholds are exceeded as well as temperature trend analysis.

Industrial Protocol

Since FLIR AX8 is Ethernet/IP and Modbus TCP compliant analysis and alarm results can easily be shared to a PLC. Digital inputs/outputs are available for alarms and control of external equipment. An image masking function allows you to select only the relevant part of the image for your analysis.

Compact and Easy to Install

Combining thermal and visual cameras in a small, affordable package, the AX8 measures only 54 x 25 x 95 mm, making it easy to install in space-constrained areas for uninterrupted condition monitoring of critical electrical and mechanical equipment.

Multiple Video Options

With AX8, you can view its thermal imagery, visible light imagery, or the two combined into FLIR's proprietary, patent pending MSX multispectral dynamic imaging. MSX provides image detail from the visible camera embossed on the thermal image, giving you, sharper edge detail, the ability to read labels and better contextual awareness.



A35/A65



FLIR A35 / A65

Extremely Affordable and Compact

FLIR's Ax5 Series models are low-cost thermal imaging temperature sensors that are ideal tools for monitoring temperatures in automation or machine vision.

High Thermal Sensitivity and Image Quality

The FLIR Ax5 Series produces high quality thermal images that can show temperature differences as small as 50 mK. Record crisp 640 x 512 pixel thermal images with the FLIR A65, or for less precise applications, the A35 generates a 320 x 256 pixel thermal image that still allows you to easily track temperature changes.

GigE Vision™ Standard Compatibility

GigE Vision is a camera interface standard developed using the Gigabit Ethernet communication interface. GigE Vision is the first standard to allow for fast image transfer using low-cost standard cables, even over long distances.

GenICam™ Protocol Support

The goal of GenICam is to provide a generic programming interface for all types of cameras. This protocol also makes it possible to use third party software with the camera.

14-bit Temperature Linear Output

Allows for non-contact temperature measurement within any third party software. A built-in Gigabit Ethernet connection allows real time 14-bit image streaming to a computer.

Synchronization

Possible to configure one camera to be master and others to be slave(s) for applications that call for more than one camera to cover the object or for stereoscopic applications.



A415/A715



FLIR A415 / A715

Excellent Image Quality

The FLIR A715 is equipped with an uncooled Microbolometer that produces crisp thermal images of 640 x 480 pixels. This allows more accuracy and shows more details at a longer distance. The FLIR A715 also has an Advanced Smart Sensor Configuration Option. Users that do not need the high image quality of the FLIR A715 can choose the A415 that produces thermal images of 320 x 240 pixels. Both cameras make temperature differences as small as 30-50 mk clearly visible, depending on the lens. They come with a built-in 24° lens with motorized focus and autofocus.

GigE Vision™

Standard Compatibility An industry first, GigE Vision is a camera interface standard developed using the Gigabit Ethernet communication interface. GigE Vision is the first standard to enable fast image transfer using low-cost standard cables even over long distances. With GigE Vision, hardware and software from different vendors can interoperate seamlessly over GigE connections.

GenICam™ Protocol Support

The goal of GenICam is to provide a generic programming interface for all kinds of cameras. The GenICam protocol also makes third-party software compatible with the camera.

Compressed 16-bit Radiometric Image Stream

Compressed 16-bit Radiometric image streaming minimizes ethernet bandwidth demands by 90%.

FLIR A700-EST™ IS



FLIR A700-EST™ IS

The FLIR A700-EST™ IS is a non-contact screening tool designed to detect elevated skin temperatures that can be a first line of defense against potential health risks. This fully integrated, scalable solution pairs the revolutionary FLIR A700 thermal camera with a high definition, user-friendly interface. Easy to deploy, the FLIR A700-EST IS detects and visualizes heat to quickly identify individuals with elevated skin temperatures. Anyone displaying an elevated temperature can then be screened using a thermometer or other medical device.

RAPID SCREENING CAPABILITY

Screens individuals in just seconds or, when used with multiple cameras in high traffic spaces, spots anomalies in skin temperatures to quickly identify individuals who may need a medical temperature check

INTUITIVE USER INTERFACE

The screening function is quickly executed by large, colored indicators on-screen. Privacy is ensured through an avatar display

DEPLOYED IN MINUTES

Simple set up: uses only two cables and PoE to operate the camera and touchscreen display. Once system is fully powered on initial set up, calibration takes approx. 10 minutes to complete before ready for use

FLIR A6XXX



FLIR A6XXX

High Sensitivity, Crisp Thermal Images

FLIR A6xxx-Series incorporates a cooled FLIR Indium Antimonide (InSb) detector that operates in the 3- to 5-micron waveband. The camera produces crisp thermal images of 640 x 512 pixels. Achieving a high thermal sensitivity of 20 mK, FLIR A6xxx-Series is able to capture the finest image details.

Fast Integration Times

Working in snapshot mode, FLIR A6xxx-Series cameras are able to capture all pixels from a scene simultaneously. This is particularly important when monitoring fast-moving objects where an uncooled thermal imaging camera would suffer from image blur. The A6600 supports image frame rates up to 480 frames per second when operating in windowing mode. The A6650 supports frame rates up to 4,175 frames per second when operating in a 16 x 4 pixel window.

Standard Video Interfaces

FLIR A6xxx-Series uses a standard GigE Vision™ / GenICam interface to transmit both commands and full dynamic range digital video. Additional interfaces include a BNC analog video output. The Gigabit Ethernet and analog video are simultaneously active yet independently controlled allowing greater flexibility for recording and display purposes.

Custom Cold Filters Available

Custom cold filtering options for specific spectral detection and measurement are available. Perfect for imaging through glass, measuring temperature of thin film plastics, filtering different wavebands for laser profiling and detection, or optical gas imaging.

Software

A Software Developer's Kit (SDK) is optionally available.



HANDHELD S



MOBILE
FLIR ONE PRO

COMPACT
FLIR C2 & C3



POINT & SHOOT
FLIR EX-XT

PROFESSIONAL
FLIR EXX



HIGH PERFORMANCE



FLIR T5X0



FLIR T8X0



FLIR T6X0



FLIR T10X0

To find the handheld right for your application, call (855) 752-3347

EMITTED ENERGY

Infrared Thermal Technologies

Camera Specs



Camera	Series	AX	Ax5		A6xx	
	Model	AX8	A35	A65	A615	
Thermal Imaging & Optical Data	Object Temperature Range	-10 to +150°C (14 to +302°F)	-25°C to +135°C (-13 to 275°F) -40°C to +550°C (-40 to 1022°F)		-20 to +150°C (-4 to 302°F) +100 to +650°C (212 to 1202°F) +300 to +2000°C (572 to 3632°F)	
	Accuracy	± 2% or 2°C (3.6°F)	± 5% or 5°C (9°F)		± 2% or 2°C (3.6°F)	
	IR Resolution	80 x 60	320 x 256	640 x 512		640 x 480
	Thermal Sensitivity	< 0.10°C @ +30°C (+86°F) / 100 mK	< 0.05°C @ +30°C (+86°F) / 50 mK		< 0.05°C @ +30°C (86°F) / 50 mK	
	Field of View (FOV)	48° x 37°	63° x 50° with 7.5 mm lens 48° x 39° with 9 mm lens 24° x 19.2° with 19 mm lens 13° x 10.8° with 35 mm lens 7.6° x 6.08° with 60 mm lens	90° x 69° with 7.5 mm lens 45° x 37° with 13 mm lens 25° x 20° with 25 mm lens 12.4° x 9.92° with 50 mm lens 6.2° x 4.96° with 100 mm lens	25° x 19° Optional lenses available	
	Focus	Fixed	Fixed / Manual		Automatic or manual (built in motor)	
	Image Frequency	9 Hz	60 Hz	30 Hz		50 Hz (100/200 Hz with windowing)
	Detector Type	Focal Plane Array (FPA), uncooled microbolometer	FPA, Uncooled VOX microbolometer		FPA, Uncooled Microbolometer	
	Detector Pitch	17 μm	25 μm	17 μm		17 μm
	Detector Time Constant	Typical 12 ms	Typical 12 ms		Typical 8 ms	
Spectral Range	7.5 - 13 μm	7.5 - 13 μm		7.5 - 14 μm		
Ethernet	Ethernet	Control, Result, Image	Control, Image		Control, Image	
	Ethernet, Type	100 Mbps	Gigabit Ethernet		Gigabit Ethernet	
	Power Over Ethernet (PoE)	Yes	Yes		No	
	Ethernet, Protocols	Ethernet/IP, Modbus TCP, TCP, UDP, SNMP, RTSP, RTP, HTTP, ICMP, IGMP, sftp, SMTP, SMB (CIFS), DHCP, MDNS (Bonjour)	TCP, UDP, ICMP, IGMP, DHCP, GigEvision		TCP, UDP, SNMP, RTSP, RTP, HTTP, ICMP, IGMP, ftp, SMTP, SMB (CIFS), DHCP, MDNS (Bonjour), uPnP, GenICam	
Digital I/O	Digital Input, Purpose	General purpose, power	General purpose, 1x opto-isolated, "0" < 2, "1" = 2-12 VDC		Image tag (start, stop, general), Image flow control, (stream on/off), Input ext. device (programmatically read)	
	Digital Output, Purpose	General purpose, function of alarm	General purpose output to ext. device (programmatically set), 1x opto-isolated, 2-40 VDC, max 185 mA		Output to ext. device (programmatically set)	
Other	Built-in Software & Analytics	Yes	No		No	
Environmental & Physical Data	Operating Temperature Range	0°C to +50°C (32°F to +122°F)	-15°C to +60°C (+5°F to +140°F)		-15°C to +50°C (+5°F to +122°F)	
	Camera Size (LxWxH)	54 x 25 x 95 mm (2.1 x 1 x 3.7 in.)	106 x 47 x 50 mm (4.2 x 1.9 x 2.0 in.)		216 x 73 x 75 mm (8.5 x 2.9 x 3.0 in.)	
	Encapsulation	IP67 (IEC 60529)	IP 40 (IEC 60529)		IP 30 (IEC 60529)	



A66xx		A400/A700		FC-Series R	
A6600	A6650	A400	A700	FC-3xx R	FC-6xx R
-20°C to 350°C (-4°F to 662°F) Optional: up to 1500°C (2732°F), up to 2000°C (3632°F)		-20 to 120°C (-4 to 248°F) 0 to 650°C (32 to 1202°F) 300 to 2000°C (572 to 3632°F)		-10°C to 110°C (14°F to 230°F)	
± 2% or 2°C (3.6°F)		± 2% or 2°C (3.6°F)		± 5% or 5°C (9°F)	
640 × 512		320 × 240	640 × 480	320 x 240	640 x 480
N/A		<30 mK, 42° @ +30°C (+86°F) <40 mK, 24° @ +30°C (+86°F) <50 mK, 14° @ +30°C (+86°F)		N/A	
Lenses Additional: 3-5µm: 13mm, 13mm (low distortion), 25mm, 50mm, 100mm (all lenses are f/2.5) 1-5µm: 25mm, 50mm, 100mm (lenses are f/2.5)		6°x4.5° with 70mm Lens 14°x10° with 29mm lens 24°x18° with 17mm Lens 42°x32° with 10mm Lens	6°x4.5° with 70mm Lens 14°x10° with 29mm lens 24°x18° with 17mm Lens 42°x32° with 10mm Lens	34° × 28° (FC-334R; 13 mm) 24° × 19° (FC-324R; 19 mm)	45° × 37° (FC-645R; 13 mm) 32° × 26° (FC-632R; 19 mm)
Manual		One-shot contrast Motorized Manual		Athermalized, focus-free	
60 Hz @ Full Window 240 Hz @ 1/2 Window 480 Hz @ 1/4 Window	125 Hz @ Full Window 409 Hz @ 1/2 Window 1077 Hz @ 1/4 Window 4175 @ 16x4 pixels Window	30 Hz		N/A	
FLIR Indium Antimonide (InSb)		Uncooled Microbolometer		Long-Life, Uncooled VOx Microbolometer	
15 µm		24 µm		25 µm	17 µm
N/A		Typical 12 ms		N/A	
3 – 5 µm or 1 - 5 µm		7.5–14 µm		7.5 - 13.5 µm	
Control, Image	DRX, Trigger In, Sync OUT	Control, result, image, and power		PoE power, communications, IP video stream	
Gigabit Ethernet		1000 Mbps		N/A	
No		Yes		Yes	
GenICam, GigE Vision 2.0		Smart - EtherNet/IP, IEEE 1588, Modbus TCP Slave, MQTT, SNMP TCP, UDP, SNTP, RTSP, RTP, HTTP, HTTPS, ICMP, IGMP, sftp (server), FTP (client), SMTP, DHCP, MDNS (Bonjour), uPnP		N/A	
N/A		Smart - NUC, NUC disable, Alarm Streaming - NUC, NUC disable, Image TAG (Start, Stop, General), Image flow control (acc. SFNC 2.3), Single frame (on trigg), Multiframe (on trigg), Continuous, Frame rate, ROI		General purpose. 6-pin terminal J8	
N/A		Smart - As function of alarm, output to external device, Fault (NC) , Streaming - Programmatically set, Fault (NC)		General purpose. 6-pin terminal J8	
No		Smart - Yes Streaming - No		Yes	
-40°C to 50°C (-40°F to 122°F)		-20 to 40°C (-4 to 104°F) (in free air) 40 to 50°C (104 to 122°F) (mounted on cooling plate accessory)		-50°C to 70°C (continuous operation) -40°C to 70°C (cold start)	
216 x 102 x 109 mm (8.5 x 4.0 x 4.3 in.) w/o lens		123 × 77 × 77 mm (4.84 × 3.03 × 3.03 in)		274 x 137 x 112 mm (10.8 x 5.4 x 4.4 in.) w/ sun shield	
N/A		IP 54, IP 66 with Hood		IP66 & IP67	

ENGINEERING SERVICES

INJECTION MOLDING PROCESS OPTIMIZATION:

Process optimization includes a complete engineering services on your molding process. Our mission is reduce your molding scrap, increase your first time quality, avoid costly warranty issues and improve your cycle time. Emitted Energy support will include a Master Molder, a Quality Engineer, and a Level 1 Thermographer on site.

INJECTION MOLDING DESIGN OF EXPERIMENT CLASSES:

Injection Molding Design of Experiment classes: Course description Design Of Experiments (DoE) for injection molding was produced in cooperation with leading DoE experts and provides an overview on how to design an experiment by explaining common terminology and teaching DoE techniques, all in an injection molding environment. This comprehensive course provides everything needed to improve your molding processes with DoE technique. Taught by a Master Molder with over 35 year of experience. Provides an overview of how to design an experiment Explores various DoE techniques Explains how to collect and analyze the data using real-world molding examples Analyzes how data is used to characterize, optimize and troubleshoot an injection molding process Explains common DoE terminology This is a 4-hour course at your facility with unlimited attendance.



ICES

IN-HOUSE BENCH STUDIES

We design and implement a capability study to tailor provide our customers with pertinent thermal data on their product. Expert thermographers create a detailed plan on gathering vital thermal figures for process improvement for you.

THERMOGRAPHY STUDIES

Proof of Concept Engineering Study. Engineer supported on-site trial of Thermal Process Monitoring System (TPMS) in a process. The trial is intended to prove solutions pathway viability and provide quantifiable data to support the customer project scope, goals, and requirements. An onsite thermal evaluation for monitoring temperature profiles of a product in a process. Engineer on-site with FLIR equipment and machine vision software for the day to evaluate the process, gather IR images, IR video, determine machine integration strategies, hardware mounting and components to engage in the solution proposal. Produce report to show images and temperature differentiation of "Pass" and "Fail" scenarios with solutions recommendations.



